

PX1318b

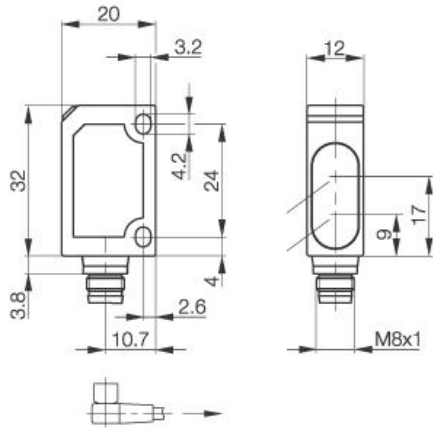

Photoelectric Sensor BKT 6K-001-P-S75 Sn=150mm Contrast sensor

Common Data

Series	BKT
Sensortype	Contrast sensor
Switching frequency	1000 Hz
Rated operating distance Sn in mm	150
asured operating distance Sa	40...150
Hysteresis	< 10% of adjusted scanning range
Indication Switching element on	yes
Indication Special funktion	Function reserve green
LED,status indicator yellow LED	
Ambient temperature	-20...+60°C
Off-delay	< 1ms
Light	Laser red light
Wavelength / Laser protection class	650nm
Sensitivity Adjustment	Teach in

Mechanical Data

Measurements	12x32x20
Housing material	ABS
Degree of protection	IP67
Connection	Connector S49 (M8,3-pin)
Weighth	40g

Electrical Data

Current	DC
Switching function	switchable
Output	PNP
Rated operational voltage Ue	24V DC
Supply Voltage	10...30V DC
Frequency of Supply Voltage	DC
No-load supply current	<25mA
Short protection	yes
Protected against polarity reversal	yes



Utilization categories
Insulation class

II

Datasheet number:

Definitions see general catalog.
If not otherwise noted, ratings according to
IEC 60947-5-2 (DIN EN60947-5-2)

Balluff GmbH
Schurwaldstrasse 9
73765 Neuhausen a.d.F.
Phone (07158) 173-0 Fax (07158) 5010

Datenblatt by CD-ROM - 04/2007

BALLUFF
sensors worldwide